

BCD-to-Decimal Decoder

General Description

The CD4028B is a BCD-to-decimal or binary-to-octal decoder consisting of 4 inputs, decoding logic gates, and 10 output buffers. A BCD code applied to the 4 inputs, A, B, C, and D, results in a high level at the selected 1-of-10 decimal decoded outputs. Similarly, a 3-bit binary code applied to inputs A, B, and C is decoded in octal at outputs 0–7. A high level signal at the D input inhibits octal decoding and causes outputs 0–7 to go LOW.

All inputs are protected against static discharge damage by diode clamps to V_{DD} and V_{SS} .

Features

- Wide supply voltage range: 3.0V to 15V
- High noise immunity: $0.45 V_{DD}$ (typ.)
- Low power TTL compatibility: fan out of 2 driving 74L or 1 driving 74LS
- Low power
- Glitch free outputs
- "Positive logic" on inputs and outputs

Applications

- Code conversion
- Address decoding
- Indicator-tube decoder

ORDERING INFORMATION

DEVICE	Package Type	MARKING	Packing	Packing Qty
CD4028BE	DIP16	CD4028B	TUBE	1000/box
CD4028BM/TR	SOP16	CD4028B	REEL	2500/reel

Connection Diagram

Pin Assignments for DIP and SOP

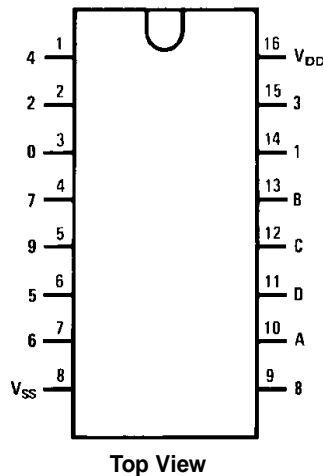

Truth Table

	D	C	B	A	0	1	2	3	4	5	6	7	8	9	
1 = HIGH Level 0 = LOW Level	0	0	0	0	1	0	0	0	0	0	0	0	0	0	BCD States
	0	0	0	1	0	1	0	0	0	0	0	0	0	0	
	0	0	1	0	0	0	1	0	0	0	0	0	0	0	
	0	0	1	1	0	0	0	1	0	0	0	0	0	0	
	0	1	0	0	0	0	0	0	1	0	0	0	0	0	
	0	1	0	1	0	0	0	0	0	1	0	0	0	0	
	0	1	1	0	0	0	0	0	0	0	1	0	0	0	
	0	1	1	1	0	0	0	0	0	0	0	1	0	0	
	1	0	0	0	0	0	0	0	0	0	0	0	1	0	
	1	0	0	1	0	0	0	0	0	0	0	0	0	1	
	1	0	1	0	0	0	0	0	0	0	0	0	1	0	Extraordinary States
	1	0	1	1	0	0	0	0	0	0	0	0	0	1	
	1	1	0	0	0	0	0	0	0	0	0	0	1	0	
	1	1	0	1	0	0	0	0	0	0	0	0	0	1	
	1	1	1	0	0	0	0	0	0	0	0	0	1	0	
	1	1	1	1	0	0	0	0	0	0	0	0	0	1	

Logic Diagram

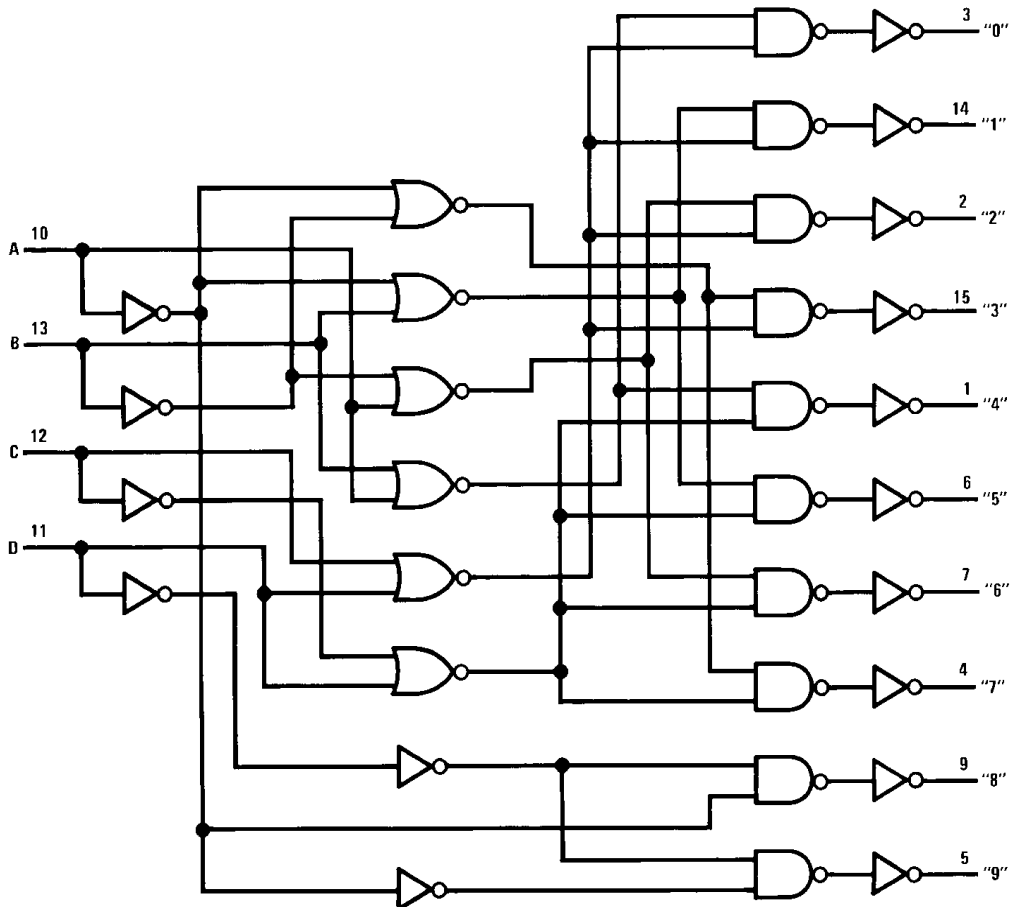

Absolute Maximum Ratings (Note 1)

(Note 2)

Supply Voltage (V_{DD})	-0.5 to +18V
Input Voltage (V_{IN})	-0.5 to V_{DD} +0.5V
Storage Temperature Range (T_S)	-65°C to +150°C
Power Dissipation (P_D)	
Dual-In-Line	700 mW
Small Outline	500 mW
Lead Temperature (T_L)	
(Soldering, 10 seconds)	260°C

Recommended Operating Conditions (Note 2)

Supply Voltage (V_{DD})	3 to 15V
Input Voltage (V_{IN})	0 to V_{DD} V
Operating Temperature Range (T_A)	-40°C to +85°C

Note 1: "Absolute Maximum Ratings" are those values beyond which the safety of the device cannot be guaranteed, they are not meant to imply that the devices should be operated at these limits. The table of "Recommended Operating Conditions" and "Electrical Characteristics" provides conditions for actual device operation.

Note 2: $V_{SS} = 0V$ unless otherwise specified.

DC Electrical Characteristics (Note 2)

Symbol	Parameter	Conditions	-40°C		+25°C			+85°C		Units
			Min	Max	Min	Typ	Max	Min	Max	
I_{DD}	Quiescent Device Current	$V_{DD} = 5V, V_{IN} = V_{DD}$ or V_{SS}		20		0.01	20		150	μA
		$V_{DD} = 10V, V_{IN} = V_{DD}$ or V_{SS}		40		0.01	40		300	μA
		$V_{DD} = 15V, V_{IN} = V_{DD}$ or V_{SS}		80		0.02	80		600	μA
V_{OL}	LOW Level Output Voltage	$ I_O < 1 \mu A, V_{IL} = 0V, V_{IH} = V_{DD}$								
		$V_{DD} = 5V$		0.05		0	0.05		0.05	V
		$V_{DD} = 10V$		0.05		0	0.05		0.05	V
		$V_{DD} = 15V$		0.05		0	0.05		0.05	V
V_{OH}	HIGH Level Output Voltage	$ I_O < 1 \mu A, V_{IL} = 0V, V_{IH} = V_{DD}$								
		$V_{DD} = 5V$	4.95		4.95	5		4.95		V
		$V_{DD} = 10V$	9.95		9.95	10		9.95		V
		$V_{DD} = 15V$	14.95		14.95	15		14.95		V
V_{IL}	LOW Level Input Voltage	$ I_O < 1 \mu A$								
		$V_{DD} = 5V, V_O = 0.5V$ or $4.5V$		1.5		2.25	1.5		1.5	V
		$V_{DD} = 10V, V_O = 1V$ or $9V$		3.0		4.5	3.0		3.0	V
		$V_{DD} = 15V, V_O = 1.5V$ or $13.5V$		4.0		6.75	4.0		4.0	V
V_{IH}	HIGH Level Input Voltage	$ I_O < 1 \mu A$								
		$V_{DD} = 5V, V_O = 0.5V$ or $4.5V$	3.5		3.5			3.5		V
		$V_{DD} = 10V, V_O = 1V$ or $9V$	7.0		7.0			7.0		V
		$V_{DD} = 15V, V_O = 1.5V$ or $13.5V$	11.0		11.0			11.0		V
I_{OL}	LOW Level Output Current (Note 3)	$V_{IH} = V_{DD}, V_{IL} = 0V$								
		$V_{DD} = 5V, V_O = 0.4V$	0.52		0.44	0.88		0.36		mA
		$V_{DD} = 10V, V_O = 0.5V$	1.3		1.1	2.2		0.9		mA
		$V_{DD} = 15V, V_O = 1.5V$	3.6		3.0	6.0		2.4		mA
I_{OH}	HIGH Level Output Current (Note 3)	$V_{IH} = V_{DD}, V_{IL} = 0V$								
		$V_{DD} = 5V, V_O = 4.6V$	-0.2		-0.16	-0.32		-0.12		mA
		$V_{DD} = 10V, V_O = 9.5V$	-0.5		-0.4	-0.8		-0.3		mA
		$V_{DD} = 15V, V_O = 13.5V$	-1.4		-1.2	-3.5		-1.0		mA
I_{IN}	Input Current	$V_{DD} = 15V, V_{IN} = 0V$		-0.3			-0.3		-1.0	μA
		$V_{DD} = 15V, V_{IN} = 15V$		0.3			0.3		1.0	μA

Note 3: I_{OL} and I_{OH} are tested one output at a time.

AC Electrical Characteristics (Note 4)

$T_A = 25^\circ\text{C}$, $C_L = 50\text{ pF}$, $R_L = 200\text{ k}$, Input $t_r = t_f = 20\text{ ns}$, unless otherwise specified

Symbol	Parameter	Conditions	Min	Typ	Max	Units
t_{PHL} or t_{PLH}	Propagation Delay Time	$V_{CC} = 5\text{V}$		240	480	ns
		$V_{CC} = 10\text{V}$		100	200	ns
		$V_{CC} = 15\text{V}$		70	140	ns
t_{THL} or t_{TLH}	Transition Time	$V_{CC} = 5\text{V}$		175	350	ns
		$V_{CC} = 10\text{V}$		75	150	ns
		$V_{CC} = 15\text{V}$		60	110	ns
C_{IN}	Input Capacitance	Any Input		5	7.5	pF

Note 4: AC Parameters are guaranteed by DC correlated testing.

Switching Time Waveforms

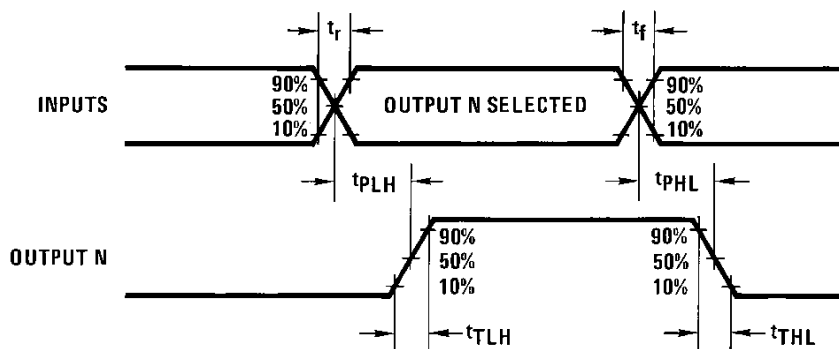

PACKAGE

SOP16

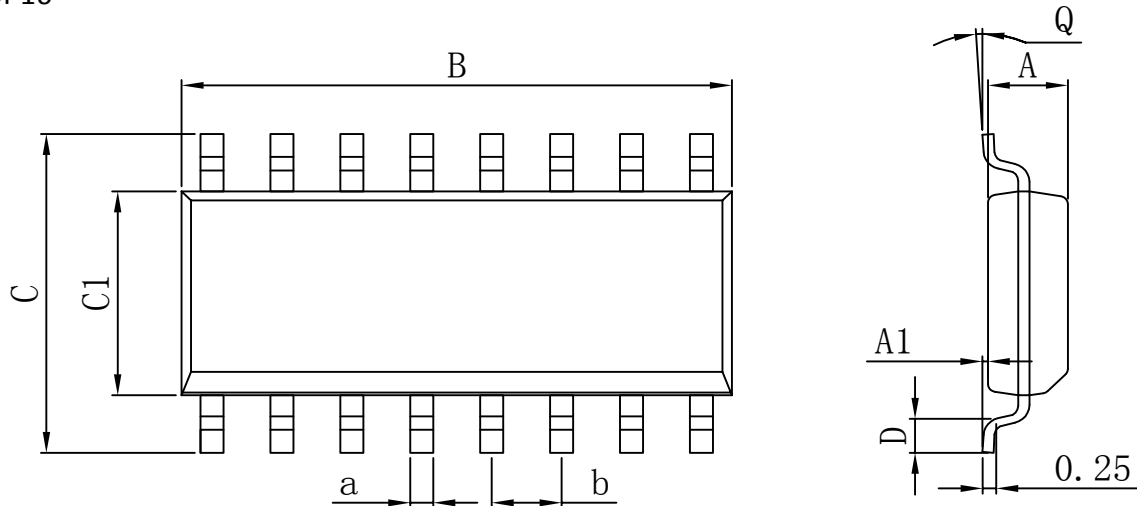

Dimensions In Millimeters					
Symbol :	Min :	Max :	Symbol :	Min :	Max :
A	4.520	4.620	D	0.400	0.950
A1	0.100	0.250	Q	0°	8°
B	9.800	10.00	a	0.420 TYP	
C	5.800	6.250	b	1.270 TYP	
C1	3.800	4.000			

DIP16

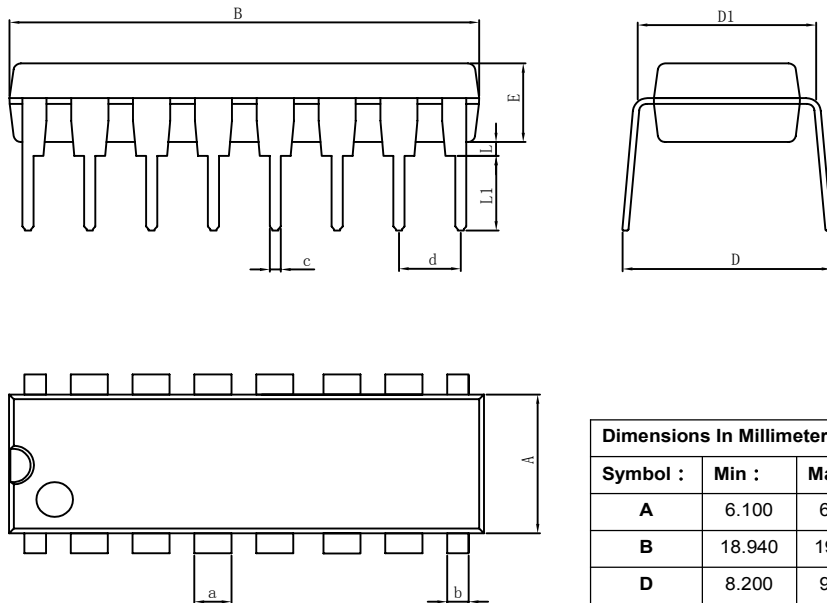

Dimensions In Millimeters					
Symbol :	Min :	Max :	Symbol :	Min :	Max :
A	6.100	6.680	L	0.500	0.800
B	18.940	19.560	a	1.524 TYP	
D	8.200	9.200	b	0.889 TYP	
D1	7.42	7.820	c	0.457 TYP	
E	3.100	3.550	d	2.540 TYP	
L	0.500	0.800			