

Features:

- Wide supply voltage range from 3V to 15V
- Fully static operation
- 5V, 10V, and 15V parametric ratings
- Standardized symmetrical output characteristics
- Inputs and outputs are protected against electrostatic effects
- Specified from -40°C to +105°C
- Packaging information: DIP14/SOP14/TSSOP14

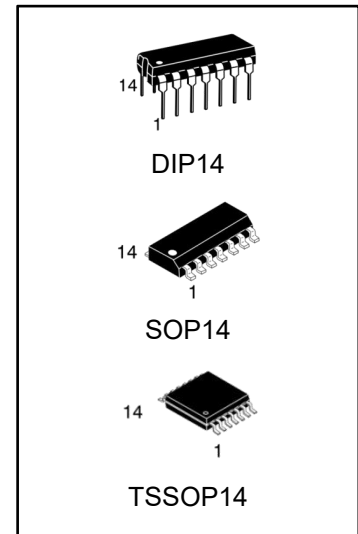

Ordering Information

DEVICE	Package Type	MARKING	Packing	Packing Qty
CD4023BE	DIP14	CD4023BE	TUBE	1000pcs/Box
CD4023BM/TR	SOP14	CD4023B	REEL	2500pcs/Reel
CD4023BMT/TR	TSSOP14	CD4023B	REEL	2500pcs/Reel

General Description

The CD4023B provides the positive triple 3-input NAND function. The outputs are fully buffered for highest noise immunity and pattern insensitivity of output impedance.

It operates over a recommended V_{DD} power supply range of 3V to 15V referenced to GND (usually ground). Unused inputs must be connected to V_{DD} , GND, or another input.

Block Diagram

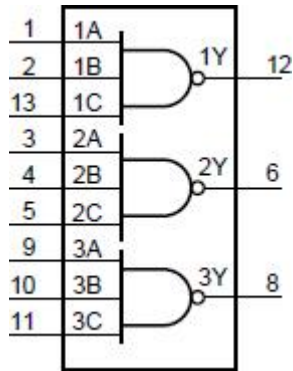

Figure 1. Functional diagram

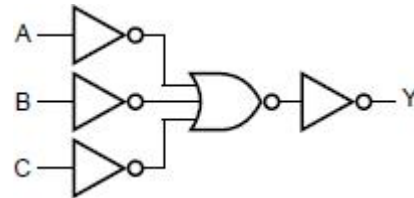
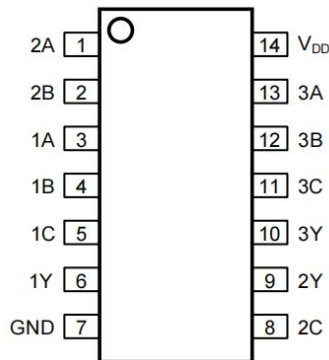

Figure 2 Logic diagram (one gate)

Pin Configurations



DIP14,SOP14,TSSOP14

Pin Description

Pin No.	Pin Name	Description
1	2A	data input
2	2B	data input
3	1A	data input
4	1B	data input
5	1C	data input
6	1Y	data output
7	GND	ground (0V)
8	2C	data input
9	2Y	data output
10	3Y	data output
11	3C	data input
12	3B	data input
13	3A	data input
14	V _{DD}	supply voltage

Function Table

Input			Output
nA	nB	nC	nY
L	X	X	H
X	L	X	H
X	X	L	H
H	H	H	L

Note: H=HIGH voltage level; L=LOW voltage level; X=don't care.

Electrical Parameter

Absolute Maximum Ratings

(Voltages are referenced to GND (ground=0V), unless otherwise specified.)

Parameter	Symbol	Conditions	Min.	Max.	Unit
supply voltage	V_{DD}	-	-0.5	+18	V
DC input current	I_{IK}	any one input	-	± 10	mA
input voltage	V_I	all inputs	-0.5	$V_{DD}+0.5$	V
storage temperature	T_{stg}	-	-65	+150	°C
total power dissipation	P_{tot}	-	-	500	mW
device dissipation	P	per output transistor	-	100	mW
Soldering temperature	T_L	10s	DIP	245	°C
			SOP	250	

Note:

- (1) For DIP14 packages: above 70°C the value of P_{tot} derates linearly with 12mW/K.
- (2) For SOP14 packages: above 70°C the value of P_{tot} derates linearly with 8mW/K.
- (3) For (T)SSOP14 packages: above 60°C the value of P_{tot} derates linearly with 5.5mW/K.

Recommended Operating Conditions

Parameter	Symbol	Conditions	Min.	Typ.	Max.	Unit
supply voltage	V_{DD}	-	3	-	15	V
ambient temperature	T_{amb}	in free air	-40	-	+105	°C

Electrical Characteristics

DC Characteristics 1

(T_{amb}=25°C, voltages are referenced to GND (ground=0V), unless otherwise specified.)

Parameter	Symbol	Conditions (V)			T _{amb} =25°C			Unit
		V _O	V _{IN}	V _D	Min.	Typ.	Max.	
supply current	I _{DD}	-	0, 5	5	-	0.01	0.25	uA
		-	0, 10	10	-	0.01	0.5	uA
		-	0, 15	15	-	0.01	1	uA
LOW-level output current	I _{OL}	0.4	0, 5	5	0.51	1	-	mA
		0.5	0, 10	10	1.3	2.6	-	mA
		1.5	0, 15	15	3.4	6.8	-	mA
HIGH-level output current	I _{OH}	4.6	0, 5	5	-0.51	-1	-	mA
		2.5	0, 5	5	-1.6	-3.2	-	mA
		9.5	0, 10	10	-1.3	-2.6	-	mA
		13.5	0, 15	15	-3.4	-6.8	-	mA
LOW-level output voltage	V _{OL}	-	0, 5	5	-	0	0.05	V
		-	0, 10	10	-	0	0.05	V
		-	0, 15	15	-	0	0.05	V
HIGH-level output voltage	V _{OH}	-	0, 5	5	4.95	5	-	V
		-	0, 10	10	9.95	10	-	V
		-	0, 15	15	14.95	15	-	V
LOW-level input voltage	V _{IL}	0.5, 4.5	-	5	-	-	1.5	V
		1, 9	-	10	-	-	3	V
		1.5, 13.5	-	15	-	-	4	V
HIGH-level input voltage	V _{IH}	4.5	-	5	3.5	-	-	V
		9	-	10	7	-	-	V
		13.5	-	15	11	-	-	V
input leakage current	I _I	-	0, 15	15	-	±10 ⁻⁵	±0.1	uA

DC Characteristics 2

(Tamb=-40°C to +105°C, voltages are referenced to GND (ground=0V), unless otherwise specified.)

Parameter	Symbol	Conditions (V)			Tamb=-40°C		Tamb=+85°C		Tamb=+105°C		Unit
		VO	VIN	VDD	Min.	Max.	Min.	Max.	Min.	Max.	
supply current	IDD	-	0, 5	5	-	0.25	-	7.5	-	7.5	uA
		-	0, 10	10	-	0.5	-	15	-	15	uA
		-	0, 15	15	-	1	-	30	-	30	uA
LOW-level output current	IOL	0.4	0, 5	5	0.61	-	0.42	-	0.36	-	mA
		0.5	0, 10	10	1.5	-	1.1	-	0.9	-	mA
		1.5	0, 15	15	4	-	2.8	-	2.4	-	mA
HIGH-level output current	IOH	4.6	0, 5	5	-0.61	-	-0.42	-	-0.36	-	mA
		2.5	0, 5	5	-1.8	-	-1.3	-	-1.15	-	mA
		9.5	0, 10	10	-1.5	-	-1.1	-	-0.9	-	mA
		13.5	0, 15	15	-4	-	-2.8	-	-2.4	-	mA
LOW-level output voltage	VOL	-	0, 5	5	-	0.05	-	0.05	-	0.05	V
		-	0, 10	10	-	0.05	-	0.05	-	0.05	V
		-	0, 15	15	-	0.05	-	0.05	-	0.05	V
HIGH-level output voltage	VOH	-	0, 5	5	4.95	-	4.95	-	4.95	-	V
		-	0, 10	10	9.95	-	9.95	-	9.95	-	V
		-	0, 15	15	14.95	-	14.95	-	14.95	-	V
LOW-level input voltage	VIL	4.5	-	5	-	1.5	-	1.5	-	1.5	V
		9	-	10	-	3	-	3	-	3	V
		13.5	-	15	-	4	-	4	-	4	V
HIGH-level input voltage	VIH	0.5,4.5	-	5	3.5	-	3.5	-	3.5	-	V
		1.9	-	10	7	-	7	-	7	-	V
		1.5,13.5	-	15	11	-	11	-	11	-	V
input leakage current	II	-	0, 15	15	-	±0.1	-	±1	-	±1	uA

AC Characteristics

(Tamb=25°C, GND=0V, tr, tf=20ns, CL=50pF, RL=200kΩ, unless otherwise specified.)

Parameter	Symbol	Conditions	Min.	Typ.	Max.	Unit	
propagation delay time	tPHL, tPLH	see Figure 4	VDD=5V	-	125	250	ns
			VDD=10V	-	60	120	ns
			VDD=15V	-	45	90	ns
transition time	tTHL, tTLH	see Figure 4	VDD=5V	-	100	200	ns
			VDD=10V	-	50	100	ns
			VDD=15V	-	40	80	ns
input capacitance	CI	any input	-	5	7.5	pF	

AC Testing Circuit

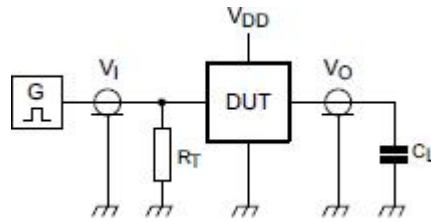

Figure 3. Test circuit for switching times

Definitions for test circuit:

DUT=Device Under Test.

CL=Load capacitance including jig and probe capacitance.

RT=Termination resistance should be equal to the output impedance Zo of the pulse generator.

AC Testing Waveforms

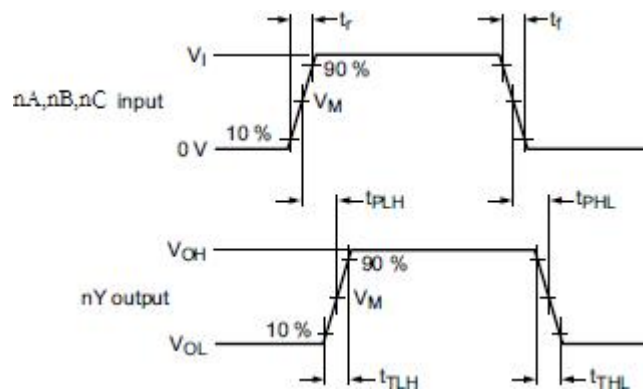

Figure 4. Propagation delay, output transition time

Measurement Points

Supply voltage	Input	Output
VDD	VM	VM
5V to 15V	0.5×VDD	0.5×VDD

Test Data

Supply voltage	Input	Load
VDD	VI	CL
5V to 15V	GND or VDD	50pF

Physical Dimensions

DIP14

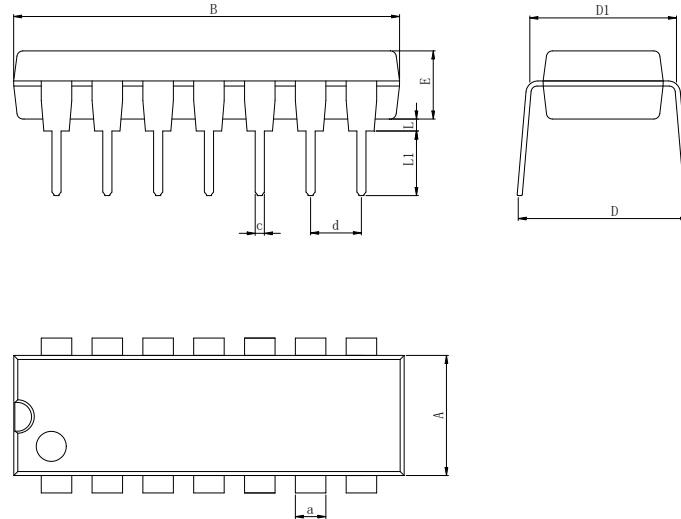

Dimensions In Millimeters(DIP14)										
Symbol:	A	B	D	D1	E	L	L1	a	c	d
Min:	6.10	18.94	8.40	7.42	3.10	0.50	3.00	1.50	0.40	2.54 BSC
Max:	6.68	19.56	9.00	7.82	3.55	0.70	3.60	1.55	0.50	

SOP14

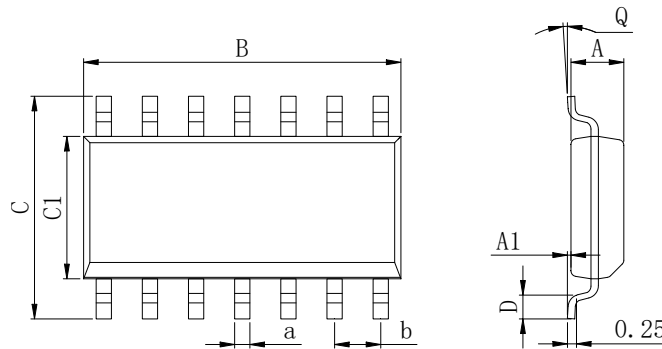

Dimensions In Millimeters(SOP14)									
Symbol:	A	A1	B	C	C1	D	Q	a	b
Min:	1.35	0.05	8.55	5.80	3.80	0.40	0°	0.35	1.27 BSC
Max:	1.55	0.20	8.75	6.20	4.00	0.80	8°	0.45	

Physical Dimensions

TSSOP14

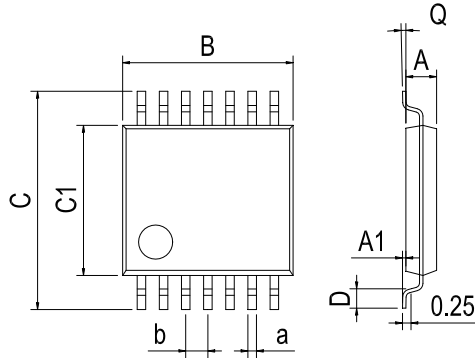

Dimensions In Millimeters(TSSOP14)									
Symbol:	A	A1	B	C	C1	D	Q	a	b
Min:	0.85	0.05	4.90	6.20	4.30	0.40	0°	0.20	0.65 BSC
Max:	0.95	0.20	5.10	6.60	4.50	0.80	8°	0.25	