

General Description

The LESD5D5.0CT1G is designed to protect voltage sensitive components from ESD and transient voltage events. Excellent clamping capability, low leakage, and fast response time, make these parts ideal for ESD protection on designs where board space is at a premium.

Applications

- Cellular phones
- Portable devices
- Digital cameras
- Power supplies

Features

- Small Body Outline Dimensions
- Low Body Height
- Peak Power up to 150 Watts @ 8 x 20 μ s Pulse
- Low Leakage current
- Response Time is Typically < 1 ns
- ESD Rating of Class 3 (> 16 kV) per Human Body Model
- IEC61000-4-2 Level 4 ESD Protection
- IEC61000-4-4 Level 4 EFT Protection

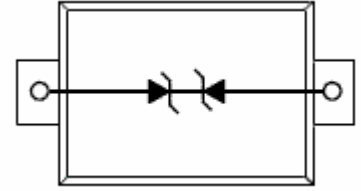

Absolute Ratings ($T_{amb}=25^{\circ}C$)

Symbol	Parameter	Value	Units	
P_{PP}	Peak Pulse Power ($t_p = 8/20 \mu s$)	150	W	
T_L	Maximum lead temperature for soldering during 10s	260	$^{\circ}C$	
T_{stg}	Storage Temperature Range	-55 to +155	$^{\circ}C$	
T_{op}	Operating Temperature Range	-40 to +125	$^{\circ}C$	
T_j	Maximum junction temperature	150	$^{\circ}C$	
	IEC61000-4-2 (ESD)	air discharge contact discharge	± 15 ± 8	KV
	IEC61000-4-4 (EFT)		40	A
	ESD Voltage	Per Human Body Model	16	KV

Electrical Parameter

Symbol	Parameter
I_{PP}	Maximum Reverse Peak Pulse Current
V_C	Clamping Voltage @ I_{PP}
V_{RWM}	Working Peak Reverse Voltage
I_R	Maximum Reverse Leakage Current @ V_{RWM}
I_T	Test Current
V_{BR}	Breakdown Voltage @ I_T

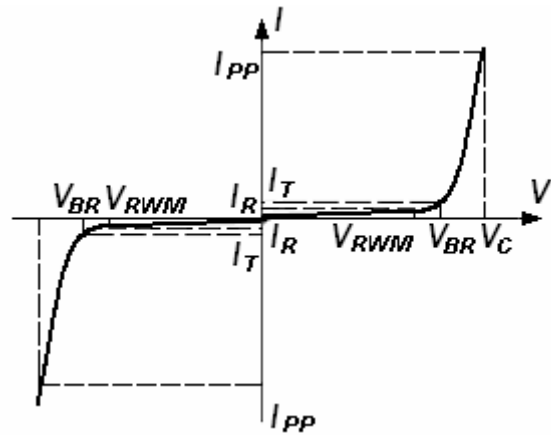

Electrical Characteristics Ratings at 25°C ambient temperature unless otherwise specified. VF = 0.9V at IF = 10mA

Device	V_{RWM} (V)	I_R (uA) @ V_{RWM}	V_{BR} (V) @ I_T (Note 1)		I_T	V_C (V) @ $I_{PP}=5 A^*$	V_C (V) @ Max I_{PP}^*	I_{PP} (A)*	P_{PK} (W)*	C (pF)
	Max	Max	Min	Max	mA	Typ	Max	Max	Max	Typ
LESD5D5.0CT1G	5.0	1	5.6	7.8	1.0	11.6	18.6	9.4	174	15

*Surge current waveform per Figure 1.

- V_{BR} is measured with a pluse test current I_T at an ambient temperature of 25°C.

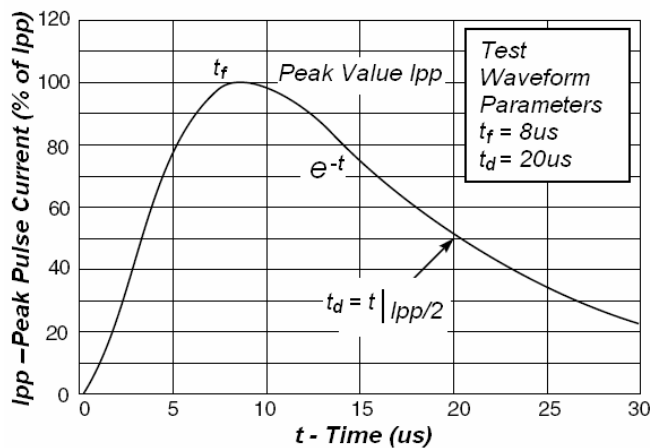

Fig1. Pulse Waveform

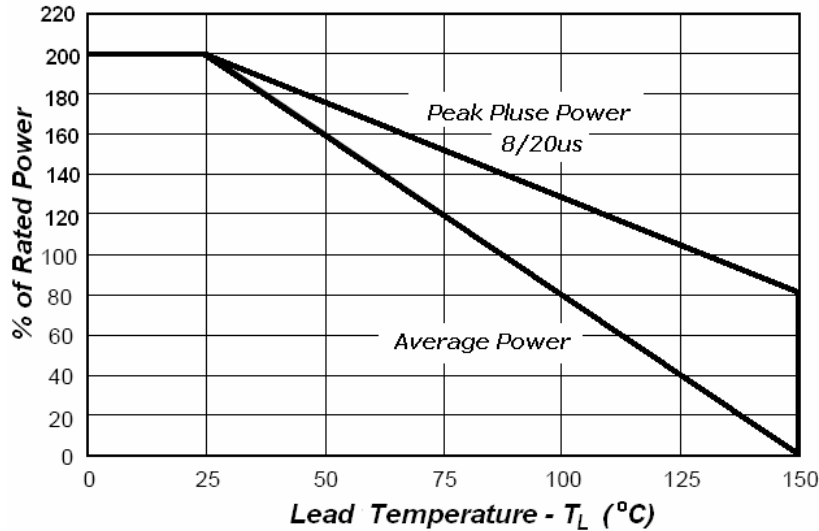

Fig2.Power Derating

Application Note

Electrostatic discharge (ESD) is a major cause of failure in electronic systems. Transient Voltage Suppressors (TVS) are an ideal choice for ESD protection. They are capable of clamping the incoming transient to a low enough level such that damage to the protected semiconductor is prevented.

Surface mount TVS offers the best choice for minimal lead inductance. They serve as parallel protection elements, connected between the signal lines to ground. As the transient rises above the operating voltage of the device, the TVS becomes a low impedance path diverting the transient current to ground. The LESD5D5.0CT1G is the ideal board level protection of ESD sensitive semiconductor components.

The tiny SOD-523 package allows design flexibility in the design of high density boards where the space saving is at a premium. This enables to shorten the routing and contributes to hardening against ESD.

Package outline dimensions

SOD-523

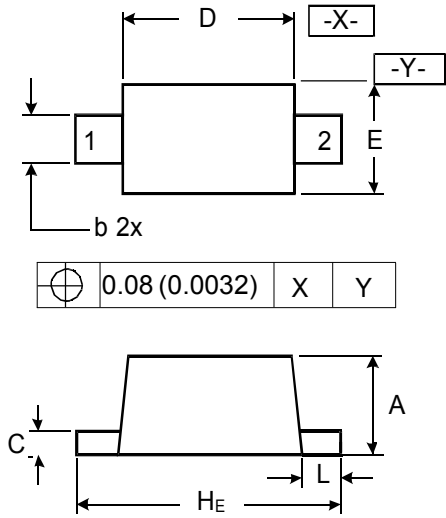

DIMENSIONS

SYMBOL	MILLIMETER		INCHES	
	MIN	MAX	MIN	MAX
A	0.50	0.70	0.020	0.028
b	0.25	0.35	0.010	0.014
C	0.07	0.20	0.0028	0.0079
D	1.10	1.30	0.043	0.051
E	0.70	0.90	0.028	0.035
H _E	1.50	1.70	0.059	0.067
L	0.15	0.25	0.006	0.010

Marking

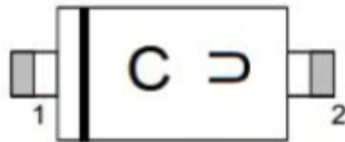

Ordering information

Order code	Package	Baseqty	Delivery mode
LES5D5.0CT1G	SOD-523	3000	Tape and reel