

SOT-23 Plastic-Encapsulate MOSFETS
FDN335N N-Channel 20-V(D-S) MOSFET

V(BR)DSS	RDS(on)MAX	ID
20 V	70mΩ@ 4.5V	1.7A
	100mΩ@ 2.5V	

FEATURE

- TrenchFET Power MOSFET
- Supper high density cell design

APPLICATION

- ※ Battery protection
- ※ Load switch
- ※ Battery management

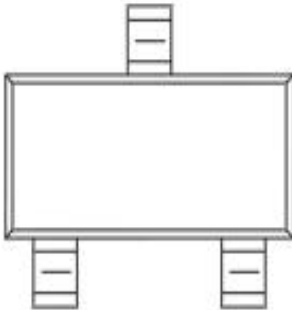
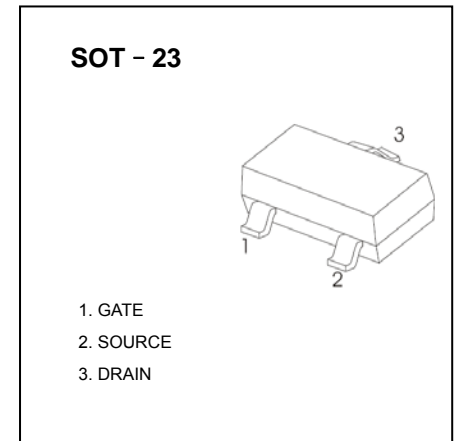
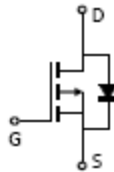
MARKING

Equivalent Circuit

Maximum ratings (Ta=25°C unless otherwise noted)

Parameter	Symbol	Value	Unit
Drain-Source Voltage	VDS	20	V
Gate-Source Voltage	VGS	±8	
Continuous Drain Current	ID	1.7	A
Pulsed Diode Current	IDM	10	
Power Dissipation	PD	1	W
Thermal Resistance from Junction to Ambient (t≤10s)	RθJA	250	°C/W
Operating Junction	TJ	150	°C
Storage Temperature	TSTG	-55~+150	°C

SOT-23 Plastic-Encapsulate MOSFETS

MOSFET ELECTRICAL CHARACTERISTICS

Static Electrical Characteristics (Ta = 25 °C Unless Otherwise Noted)

Parameter	Symbol	Test Condition	Min	Typ	Max	Unit
Static						
Drain-source breakdown voltage	V(BR)DSS	VGS = 0V, ID = 250μA	20			V
Gate-source threshold voltage	VGS(th)	VDS = VGS, ID = 250μA	0.4		1.5	V
Gate-source leakage	IGSS	VDS = 0V, VGS = ±8V			±100	nA
Zero gate voltage drain current	IDSS	VDS = 16V, VGS = 0V			1	μA
Drain-source on-state resistancea	RDS(on)	VGS = 4.5V, ID = 1.7A		55	70	mΩ
		VGS = 2.5V, ID = 1.5A		78	100	mΩ
Forward transconductancea	gfs	VDS = 4.5V, ID = 1.7A		7		S
Diode forward voltage	VSD	IS = 1A, VGS = 0V		0.8	1.2	V
Dynamic						
Input capacitance	Ciss	VDS = 10V, VGS = 0V, f = 1MHz		310		pF
Output capacitance	Coss			80		pF
Reverse transfer capacitanceb	Crss			40		pF
Total gate charge	Qg	VDS = 10V, VGS = 4.5V, ID = 1.7A		3.5		nC
Gate-source charge	Qgs			0.6		nC
Gate-drain charge	Qgd			1		nC
Gate resistance	Rg	f = 1MHz	0.5		2.2	Ω
Switchingbtr						
Turn-on delay time	td(on)	VDS = 10V RL = 3.5Ω, ID ≈ 1A, VGEN = 4.5V, Rg = 3Ω		5		ns
Rise time	tr			8.5		ns
Turn-off delay time	td(off)			11		ns
Fall time	tf			3		ns
Drain-source body diode characteristicstr						
Continuous Source-Drain Diode Current	IS	Tc = 25°C			1.2	A
Pulsed Diode forward Curren	ISM				10	A

Note :

1. Repetitive Rating : Pulse width limited by maximum junction temperature.
2. Surface Mounted on FR4 Board, t < 10 sec.
3. Pulse Test : Pulse Width ≤ 300μs, Duty Cycle ≤ 2%.
4. Guaranteed by design, not subject to production testing.

SOT-23 Plastic-Encapsulate MOSFETS

SOT-23 PACKAGE OUTLINE DIMENSIONS

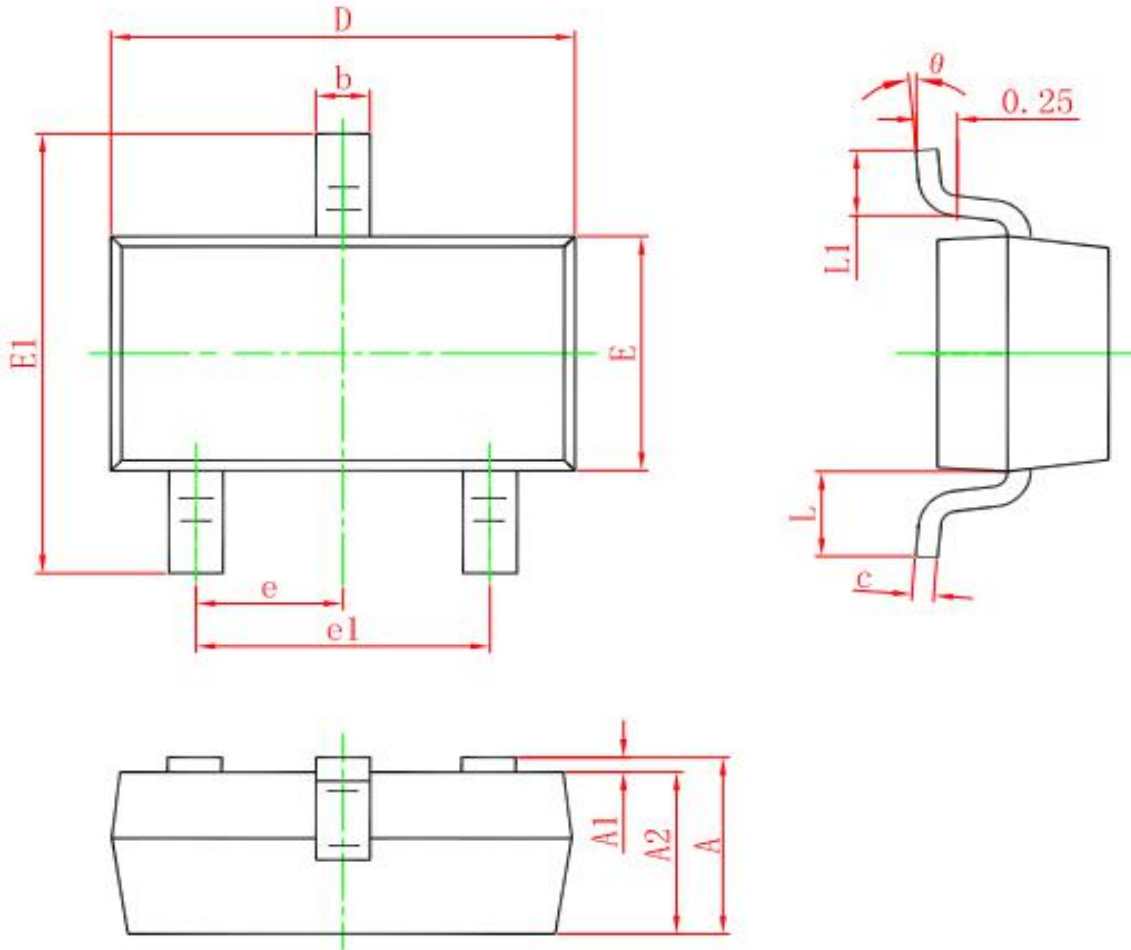

Symbol	Dimensions In Millimeters		Dimensions In Inches	
	Min.	Max.	Min.	Max.
A	0.900	1.150	0.035	0.045
A1	0.000	0.100	0.000	0.004
A2	0.900	1.050	0.035	0.041
b	0.300	0.500	0.012	0.020
c	0.080	0.150	0.003	0.006
D	2.800	3.000	0.110	0.118
E	1.200	1.400	0.047	0.055
E1	2.250	2.550	0.089	0.100
e	0.950 TYP.		0.037 TYP.	
e1	1.800	2.000	0.071	0.079
L	0.550 REF.		0.022 REF.	
L1	0.300	0.500	0.012	0.020
θ	0°	8°	0°	8°